



OFFICE DESIGN ADDS TO FIRM'S ASSETS.

When an asset management firm in Boston, Massachusetts, moved into a new 8,400 square foot office suite, management wanted a space that itself was an asset to the firm. In order to create an environment that was rich and warm, the need arose for custom architectural woodwork.

◀ THE SPACIOUS ELLIPSE ATRIUM is highlighted by horizontal and vertical bands of Maple and saw tooth bay windows.



Asset Management Company Offices

▲ TRADITIONAL CHERRY RECEPTION DESK and doors in the reception area are given a European flair with the addition of a British telephone booth.

Company executives brought in the design firm of Margulies & Associates, Boston, to create a classic, impressive space that complements the firm's working style and culture. A boardroom and public reception spaces were desired to provide a comfortable and professional environment for staff and international clients.

Interior architecture featured custom architectural woodwork, fabricated by Trickett Woodworks, an AWI member firm located in Auburn, New Hampshire. Cherry was used throughout for window wall systems, wainscot, full height wall paneling, the reception desk, standing and running trim, door frames, credenzas and casework. All matching was sequenced and balanced. High pressure decorative laminate was used for counter tops.

DESIRED DESIGN

With a focus on investing in European companies, the client asked

the design firm to create a finely-detailed office suite inspired by classic Continental and American interiors. Because the staff keeps long and unusual hours related to the firm's international interests, management wanted to provide comfortable staff areas for relaxation and informal collaboration.

In addition, reports Margulies & Associates' John Pearson, AIA, the somewhat irregular shape of the space lent itself to a zoned plan with a natural separation between different functional areas.

"We organized the irregular floor plan into three distinct functional zones," says Pearson, "based upon the company's unique working style: a reception and visitor waiting area, a conference center and an open trading floor. Consolidating public spaces such as the reception area and conference center at one end of the suite provided a large open area for the trading operation."

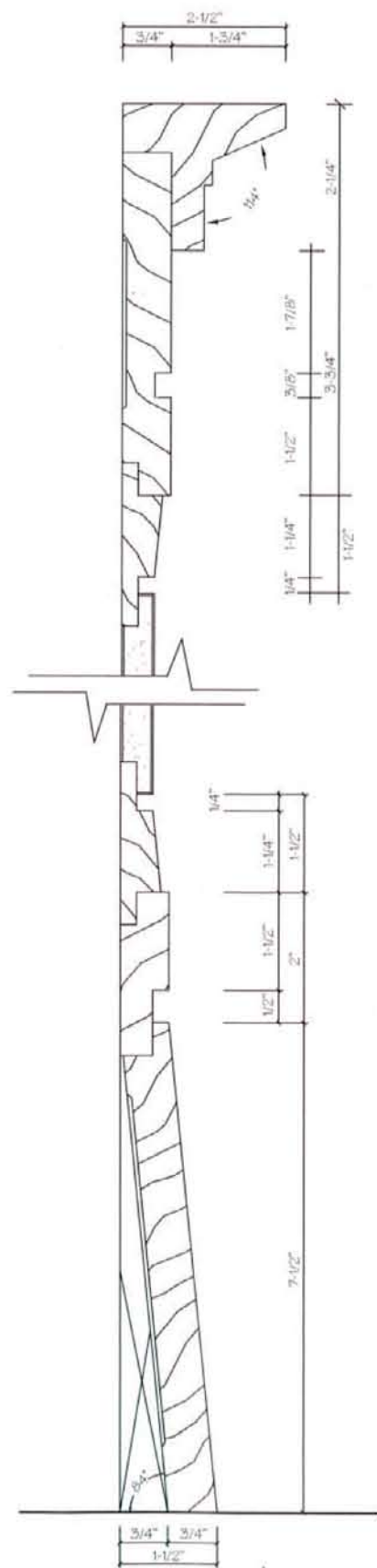

○ WAINSCOT PANELING
Vertical Section

Formal areas are finished with Mahogany parquet flooring, Cherry wainscot and paneling and marble counter surfaces.

Glass-front private offices are arranged with wide views over the trading floor, ensuring that executives can remain fully involved in trading operations throughout the day.

A welcoming staff kitchen features limestone tile flooring, a stainless steel tile backsplash and black granite countertops. Adjacent to the kitchen is a staff living area and game room.

MEETING OBJECTIVES

"Our review of the project addressed design issues regarding the detailing," notes Charlie Trickett of the woodworking firm. "We worked with the architect to maintain design intent and maximize constructability throughout the project."

Because the project was on a fast-track schedule, completed in seven



Asset Management Company Offices

▲ COMFORTABLE AREAS FOR RELAXATION and informal collaboration are provided for the staff.
▼ THE CONFERENCE CENTER is accented with elegant Cherry wainscot and window walls.





THE TRADING OPERATION is situated in a large open area. Executive offices look out onto the trading floor.



months, many decisions needed to be made quickly. "Working closely with John Pearson proved to be an asset to Trickett Woodworks," continues Trickett. "We were able to address issues as they arose with a simple sketch, enabling the team to maintain momentum."

According to Pearson, the owner was interested in an unusually high level of quality and creating a highly-detailed space, specifically regarding the architectural woodwork. "This created an exciting challenge throughout the project."

Major considerations were the tone, lines and grain of the wood, and how it impacts the design of the office. Samples were provided by the woodworker and architect with the final choice resting with the owner.

SUPERB WORKMANSHIP

The scale and intricate detail of the two full-height paneled walls make them especially noteworthy, says Pearson – one with wainscot and borrowed lights into the conference rooms, and another of wainscot and veneer panels.

"Our work with Trickett Woodworks was truly collaborative. All significant project details were reviewed together before the shop drawings were produced. This created a trusted project team that was able to deliver a highly successful project."

Trickett Woodworks was involved in the project from the very beginning, adds owner Robert Needham. "We enjoyed working with them on this project, which was the second time we've worked together, and we continue to appreciate their high quality workmanship."

"We have received many compliments from clients and visitors, many of whom travel extensively and experience many different kinds of office spaces. The hallway to the main boardroom is the focal point of our space, with a high level of woodwork detail."

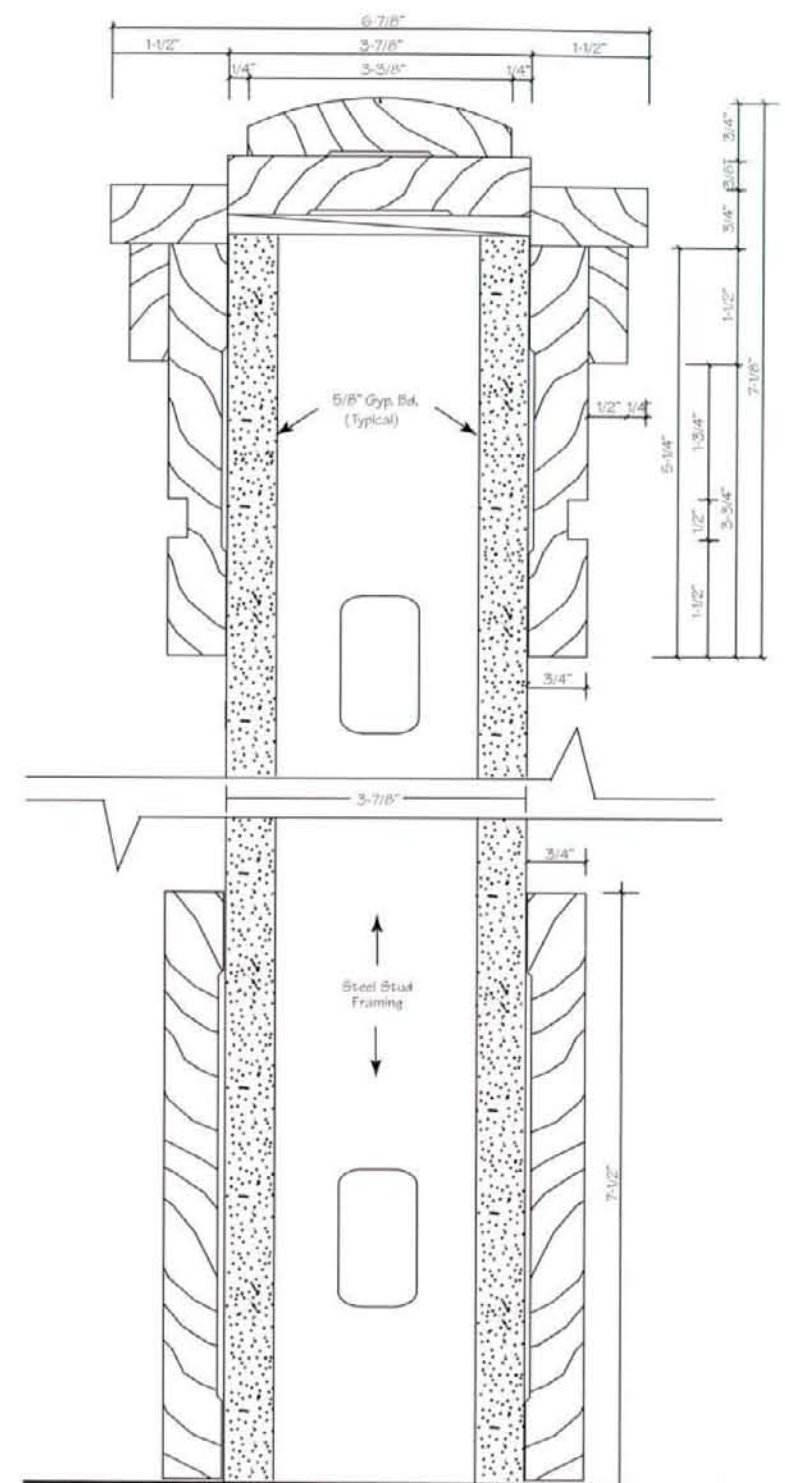

KNEE WALL VERTICAL SECTION
Wall Cap & Base Board Details

Project:	Asset Management Company Offices	Boston, MA
Woodworker:	Trickett Woodworks	Auburn, NH
Architect:	Margulies & Associates	Boston, MA
General Contractor:	cm&b	Lynnfield, MA
Photographer:	Warren Patterson	Upper Falls, MA